

Tolerance grade	Basic dimension range (mm)							
	0.5~3	>3~6	>6~30	>30~120	>120~400	>400~1000	>1000~2000	>2000~4000
Precision f	±0.05	±0.05	±0.1	±0.15	±0.2	±0.3	±0.5	-
Medium m	±0.1	±0.1	±0.2	±0.3	±0.5	±0.8	±1.2	±2

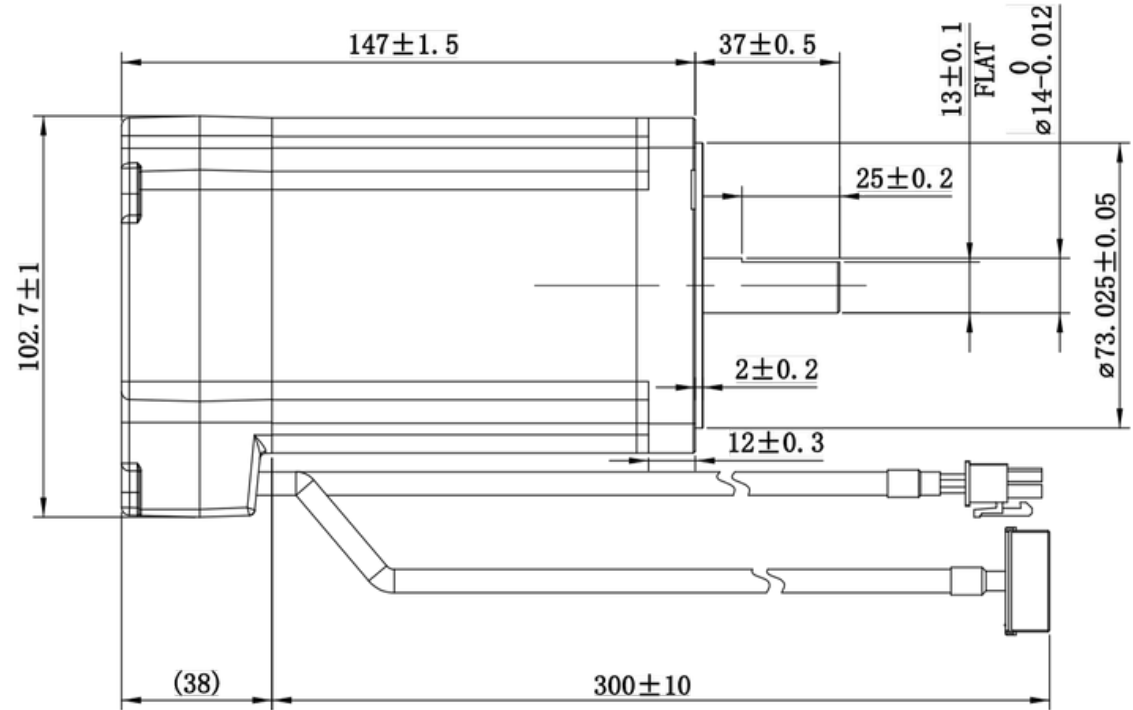

Wiring Diagram

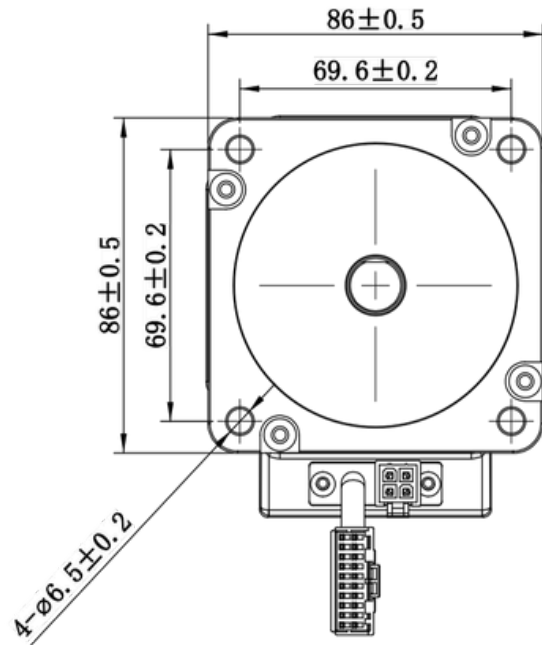
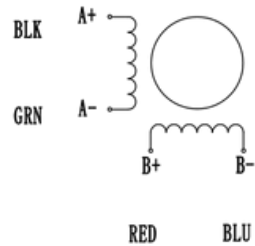

Exciting Sequence vs. Direction of Rotation

STEP	A+	B+	A-	B-	CCW
1	+	+	-	-	↑
2	-	+	+	-	
3	-	-	+	+	
4	+	-	-	+	

Clockwise view from mounting side

BO		2024/06/13		AM34SS5DGA-N		4696351002236	
Mark	Change Order No.	Date		Design stage	Weight	Scale	
Designed by	Process	Approved by		D		2:1	
Checked by	Approved by	Reviewed by		Page		1 of 2	
Reviewed by							

First used model

A3538

1 / 1

View

Tolerance grade	Basic dimension range (mm)							
	0.5~3	>3~6	>6~30	>30~120	>120~400	>400~1000	>1000~2000	>2000~4000
Precision f	±0.05	±0.05	±0.1	±0.15	±0.2	±0.3	±0.5	-
Medium m	±0.1	±0.1	±0.2	±0.3	±0.5	±0.8	±1.2	±2

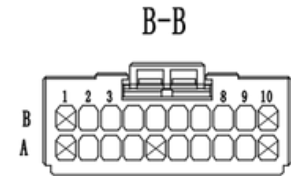
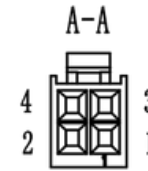

Motor Definition	
PIN	Color
1	Blue (B-)
2	Red (B+)
3	Green (A-)
4	Black (A+)

Encoder Definition	
PIN	Color
B1	
B2	White/Black (W-)
B3	Grey/Black (V-)
B4	Brown/Black (U-)
B5	Shield
B6	Black (GND)
B7	Yellow/Black (Z-)
B8	Green/Black (B-)
B9	Blue/Black (A-)
B10	
A1	
A2	White (W+)
A3	Grey (V+)
A4	Brown (U+)
A5	
A6	Red (+5V)
A7	Yellow (Z+)
A8	Green (B+)
A9	Blue (A+)
A10	

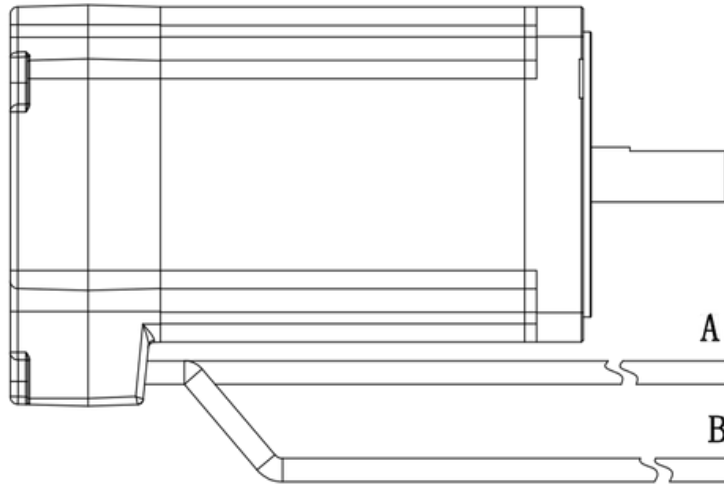

HOUSING: 39-01-3048 (MOLEX)
 TERMINAL: 39-00-0038 (MOLEX)

HOUSING: 1-1827864-0 (TYCO)
 TERMINAL: 1871303-1 (TYCO)

Specifications

1. Number of Phase	2
2. Step Angle	1.8°
3. Phase Resistance	0.25±0.10ohm(20° C)
4. Phase Inductance	2.8mH±20%(1kHz 1V rms)
5. Peak Current	10A
6. Holding Torque	9.5Nm Typ. (Two phase on rated current)
7. Rotor Inertia	2200gcm ²
8. Dielectric strength	500V AC 1 minute
9. Insulation Resistance	More than 100MΩ
10. Insulation Class	B(130℃)
11. Using Temperature	-20℃~+50℃
12. Using Humidity	15%~85%
13. IP Level	IP20
14. Encoder Resolution	20000 Counts

BO	2024/06/13	AM34SS5DGA-N	4696351002236		
Mark	Change Order No.	Date	Drawing stage	Weight	Scale
Designed	Process		D		2:1
Checked	Approved		Page 2 of 2		
Reviewed					

First used model

A3538

1 / 1

View